

XP-600

Small-in-One™ Printer



Quick Guide

About Your Product	2
Loading Paper	4
Copying a Document or Photo	9
Printing From a Memory Card	10
Printing From Your Computer	12
Scanning a Document or Photo	16
Maintaining Your Product	19
Solving Problems	26
Notices	32

About Your Product

After you set up your XP-600 (see the *Start Here* sheet), turn to this *Quick Guide* and your online *User's Guide* for instructions on using your product.

Features	Where to find information
Copy and scan from the easy-to-use touch panel.	See this <i>Quick Guide</i> for the basics. See the online <i>User's Guide</i> for details.
Easy wireless networking.	See the <i>Start Here</i> sheet and the online <i>User's Guide</i> .
Print photos from a USB flash drive, external hard drive, or CD burner.	See the online <i>User's Guide</i> for details.
Copy files to and from your computer with the built-in memory card reader.	
Print and scan from anywhere with EPSON Connect™ Solutions, and Google Cloud Print™.	See www.epson.com/connect and the online <i>User's Guide</i> for details.

Adjusting the Control Panel

The control panel is adjustable. Raise or lower it to the desired angle as shown.

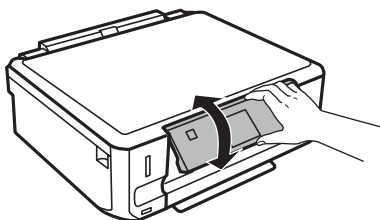

Using the Touch Panel

The touch panel makes it easy to use all the features of your product. To save energy, the screen goes dark after several minutes of inactivity. Touch the panel to wake it up.

The touch panel displays only the buttons that are available for the task you are working on.

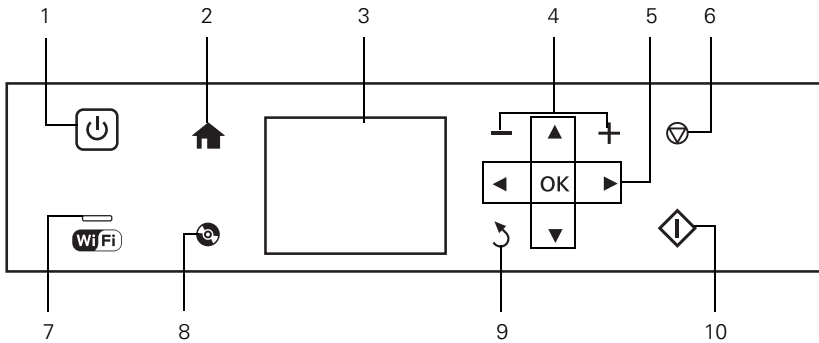

Number	Description
1	Turns product on/off
2	Returns to the Home menu
3	LCD screen shows menus and status
4	Sets the number of copies
5	Use the arrow keys and OK button to navigate menus
6	Stops copying/printing/scanning or resets settings
7	Shows wireless network status
8	Opens the CD/DVD menu
9	Cancels/returns to the previous menu
10	Starts copying/printing/scanning

Caution: Press the touch panel gently with the tip of your finger; don't press too hard or use sharp objects.

Tip: To turn off the "beep" heard when you press a button, or to reduce its volume, press ◀ or ▶ to select **Setup**, press **OK** > **Printer Setup** > **OK** > **Sound** > **OK** and adjust one of the settings.

Note: The **WiFi** light is green when the product is connected to a network. It flashes when network settings are being adjusted (green for wireless and orange for wired).

For more information on the icons displayed on the screen, press ◀ or ▶, then select **Help** on the product's touch panel.

Loading Paper

Your printer has two paper cassettes. You can load the following paper sizes:

- Upper cassette (Cassette 1): 4 × 6- or 5 × 7-inch photo paper
- Lower cassette (Cassette 2): letter-size, A4, legal-size, 4 × 6-, 5 × 7-, or 8 × 10- inch paper

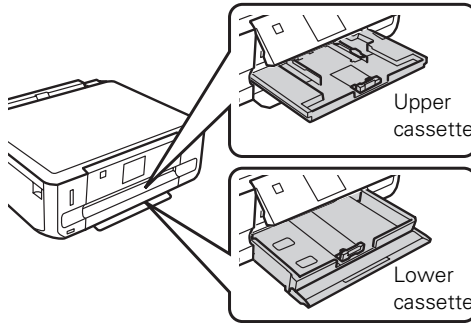

For details on loading paper in the lower cassette, see the *Start Here* sheet. To load paper in the upper cassette, follow the instructions in this section.

Loading Paper in the Upper Cassette

1. Open the front cover. If the output tray is open, close it before going to the next step. (As you slide in the output tray, there may be slight resistance and noise. This is normal.)

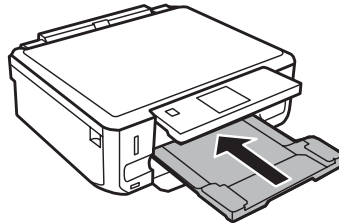
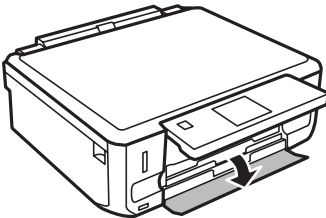

2. Pull out the upper paper cassette.

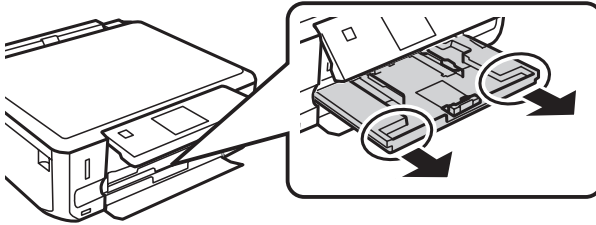

Note: If you do not see the upper cassette, it may be pushed into the printer. Remove the lower cassette, then carefully pull out the upper cassette.

3. Slide the edge guides outward.

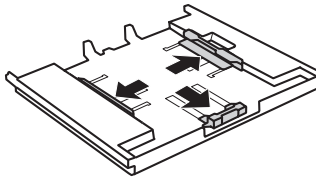

4. Set the front edge guide to the paper size you are using. Then insert paper with the glossy or printable side facedown. Make sure the paper is loaded against the front edge guide.

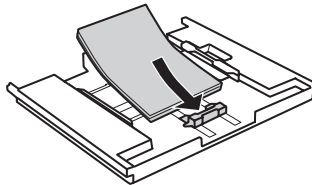

5. Slide the side edge guides against the paper, but not too tight. Make sure the paper is under the tabs on the edge guides.

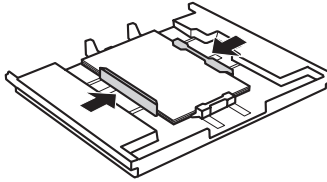

6. Keep the cassette flat as you insert it. Insert the cassette until the arrows on the right side line up.

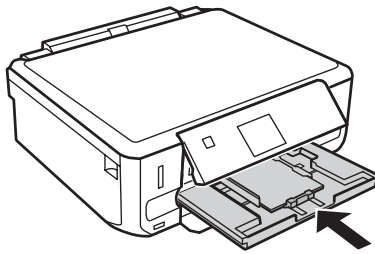

Using Special Papers

Epson offers a wide array of high quality papers, making it easy to maximize the impact of your documents, photos, presentations, and creative projects.

You can purchase genuine EPSON ink and paper at EPSON® Supplies Central® at www.epson.com/ink3 (U.S. sales) or www.epson.ca (Canadian sales). You can also purchase supplies from an EPSON authorized reseller. To find the nearest one, call 800-GO-EPSON (800-463-7766).

Paper name	Size	Part number	Sheet count
EPSON Bright White Paper	Letter (8.5 × 11 inches [216 × 279 mm])	S041586	500
EPSON Brochure & Flyer Paper Matte Double-sided	Letter (8.5 × 11 inches [216 × 279 mm])	S042384	150
EPSON Ultra Premium Presentation Paper Matte	Letter (8.5 × 11 inches [216 × 279 mm])	S041341	50
EPSON Premium Presentation Paper Matte	8 × 10 inches (203 × 254 mm)	S041467	50
	Letter (8.5 × 11 inches [216 × 279 mm])	S041257 S042180	50 100
EPSON Premium Presentation Paper Matte Double-sided	Letter (8.5 × 11 inches [216 × 279 mm])	S041568	50
EPSON Presentation Paper Matte	Letter (8.5 × 11 inches [216 × 279 mm])	S041062	100
	Legal (8.5 × 14 inches [216 × 356 mm])	S041067	100
EPSON Ultra Premium Photo Paper Glossy	4 × 6 inches (102 × 152 mm)	S042181 S042174	60 100
	5 × 7 inches (127 × 178 mm)	S041945	20
	8 × 10 inches (203 × 254 mm)	S041946	20
	Letter (8.5 × 11 inches [216 × 279 mm])	S042182 S042175	25 50
EPSON Ultra Premium Photo Paper Luster	Letter (8.5 × 11 inches [216 × 279 mm])	S041405	50
EPSON Premium Photo Paper Glossy	4 × 6 inches (102 × 152 mm)	S041808 S041727	40 100
	5 × 7 inches (127 × 178 mm)	S041464	20
	8 × 10 inches (203 × 254 mm)	S041465	20
	Letter (8.5 × 11 inches [216 × 279 mm])	S042183 S041667	25 50
EPSON Premium Photo Paper Semi-gloss	4 × 6 inches (102 × 152 mm)	S041982	40
	Letter (8.5 × 11 inches [216 × 279 mm])	S041331	20

Paper name	Size	Part number	Sheet count
EPSON Photo Paper Glossy	4 × 6 inches (102 × 152 mm)	S041809 S042038	50 100
	Letter (8.5 × 11 inches [216 × 279 mm])	S041141 S041649 S041271	20 50 100
EPSON Photo Quality Self-adhesive Sheets	A4 (8.3 × 11.7 inches [210 × 297 mm])	S041106	10
EPSON Iron-on Cool Peel Transfer paper	Letter (8.5 × 11 inches [216 × 279 mm])	S041153	10

Note: Media availability varies by country.

For additional paper loading instructions, see the *Start Here* sheet or online *User's Guide*.

For best results:

- Fan and align the edges of the paper before loading.
- If the paper is curled, flatten it or curl it slightly in the opposite direction before loading. Printing on curled paper may cause ink to smear on your prints.
- Load paper into the paper cassettes with the glossy or printable side facedown making sure the paper is under the edge guides.
- Always load paper short edge first and make sure the paper stack fits under the edge guides.
- Make sure the paper is loaded against the edge guide and not sticking out from the end of the cassette.
- Do not load more than the recommended number of sheets.

Copying a Document or Photo

Follow the steps in this section to position your originals correctly on the scanner glass and make color or black-and-white copies.

1. Make sure paper is loaded in one of the paper cassettes (see page 4).
2. Open the document cover and place your original facedown on the scanner glass, with the bottom against the front-right corner.

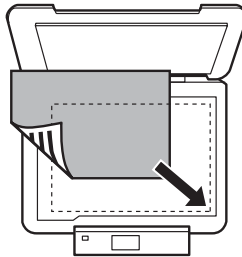

3. Close the cover gently so you don't move the original.
4. Press if necessary, press or to select **Copy**, then press **OK**. You see this screen:
5. Press or to select the number of copies you want (up to 99).
6. Press or to select **Color** or **B&W** (black-and-white) copies.
7. Press or , select **Paper** and **Copy Settings**, then press **OK** to view additional copy settings.
8. Press or to select a copy setting, then press or to change the selected setting.

Note: To clear previously used copy settings, press . For more information about copy settings, see your online *User's Guide*.

9. When you're ready to copy, press .
To cancel copying, press .

Note: When printing two-sided, if ink on the front of the paper smears, select a longer Dry Time setting.

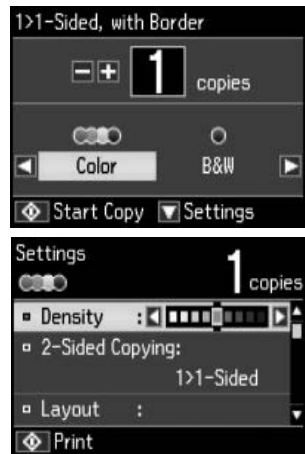

Printing From a Memory Card

Your printer lets you print photos directly from your digital camera's memory card; just insert it into the memory card slot and you're ready to print.

See the online *User's Guide* for a list of compatible memory cards and instructions on copying memory card files between your printer and a computer.

Inserting the Card

1. Make sure your printer is turned on.
2. Insert your card as shown.

Caution: Do not force the card into the slot; it won't go in all the way. If your memory card requires an adapter, attach it before inserting the card into the slot. Otherwise, the card might get stuck.

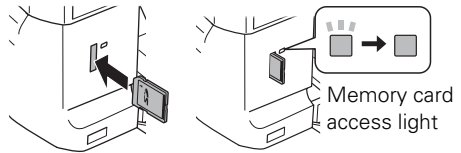

The memory card access light flashes, then stays lit. Now you can view your photos on the LCD screen and print them (see page 11).

Removing the Card

After you finish printing your photos, follow these steps to remove the card:

1. Make sure the memory card access light is not flashing.

Caution: Do not remove the card or turn off your printer while the memory card access light is flashing; you may lose data on the card.

2. If the printer is connected to your computer with a USB cable, do one of the following before removing the memory card or turning off the printer:
 - **Windows:** Right-click the name of your card (removable disk) in Computer, My Computer or Windows Explorer, and select **Eject**.
 - **Mac OS X:** Drag the  removable disk icon from your desktop into the trash.
3. Pull the card straight out of its slot.

Printing Photos From the LCD Screen

You can select individual photos for printing as you view them on the LCD screen. See the online *User's Guide* for instructions on printing various types of layout sheets and personalized note paper.

1. Load several sheets of EPSON photo paper (various types available; see page 7).
 2. Press **↑** if necessary, press **◀** or **▶** to select **Print Photos**, then press **OK**.
 3. Press **◀** or **▶** to scroll through your photos and display one that you want to print.
 4. Press **+** or **-** to select the number of copies you want of that photo.
 5. To select settings, press **▼**.
 6. Select the settings you want to change, then press **OK** and change settings as necessary. You can select the following:
 - **Select Photos** to view and select all photos or photos by date
 - **Display Mode** to view 9 small thumbnail images on the LCD screen
 - **Print Settings** to change the paper size, paper type, borders, and other print settings
 - **Photo Adjustments** to change brightness, contrast, fix red eye, and other image adjustments
 - **Crop/Zoom** to zoom into your photo and crop the printed image
- For more information on these features, see the online *User's Guide*.
7. Repeat steps 3 and 4 to select more photos.
 8. When you're ready to print, press **◇**.
To cancel printing, press **⊗**.



Printing From Your Computer

This section describes the basic steps for printing from a Windows® or Mac computer. For detailed instructions on printing, including two-sided printing on plain paper or EPSON Bright White Paper with the auto duplexer, see the online *User's Guide*.

Printing in Windows

1. Select the print command in your application.

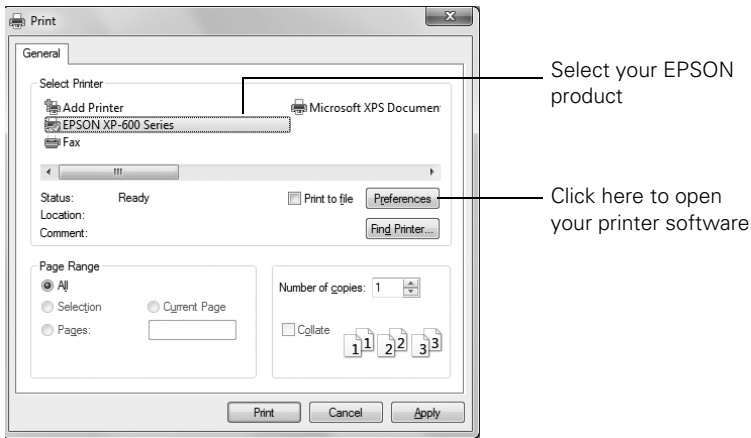

2. Select your product, then click the **Preferences** or **Properties** button.
(If you see a **Setup**, **Printer**, or **Options** button, click it. Then click **Preferences** or **Properties** on the next screen.)

3. On the Main tab, select the basic print settings. Make sure you choose the correct paper **Source** and **Type** setting for the paper you are using (see page 15 for details).

Select the type of document you're printing (choose **Photo** or **Best Photo** for pictures)

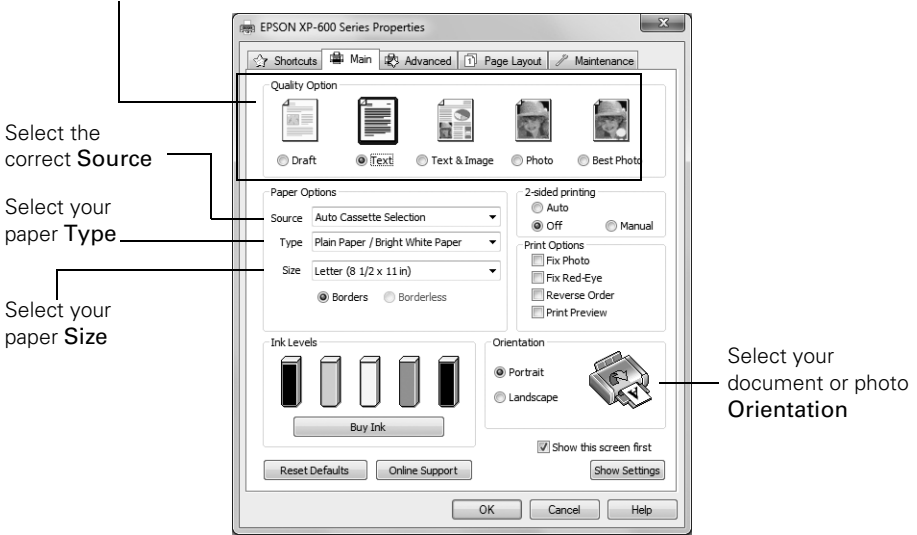

Select the correct **Source**

Select your paper **Type**

Select your paper **Size**

Select your document or photo **Orientation**

Tip: For quick access to the most common settings, click the **Shortcuts** tab and select one of the **Printing Presets**. You can create your own presets by clicking the **Add/Remove** button.

4. To resize your printout or select other print settings, click the **Page Layout** tab and select settings as necessary.
5. For more printing options, click the **Advanced** tab.

Note: For more information about print settings, click **Help** or see your online *User's Guide*.

6. Click **OK** to save your settings.
7. Click **OK** or **Print** to start printing.

Printing with Mac OS X

Follow the steps below to print from Mac OS X.

1. Open a photo or document in an application.
2. Open the File menu and select Print.
3. Select your EPSON product as the Printer setting.

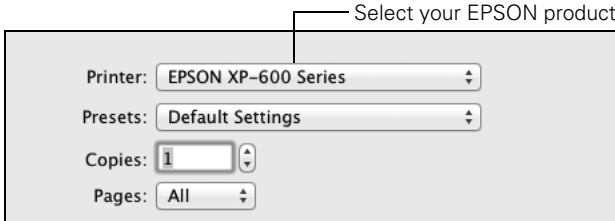

4. Click the arrow or **Show Details** to expand the print window, if necessary.
5. Select basic copy and page settings. For borderless printing, choose a **Paper Size** setting with a **Borderless** option.

Note: If the setting you want isn't shown (for example, **Scale**), check for it in your application before printing. Or select your application from the pop-up menu in this window and check if the setting is available.

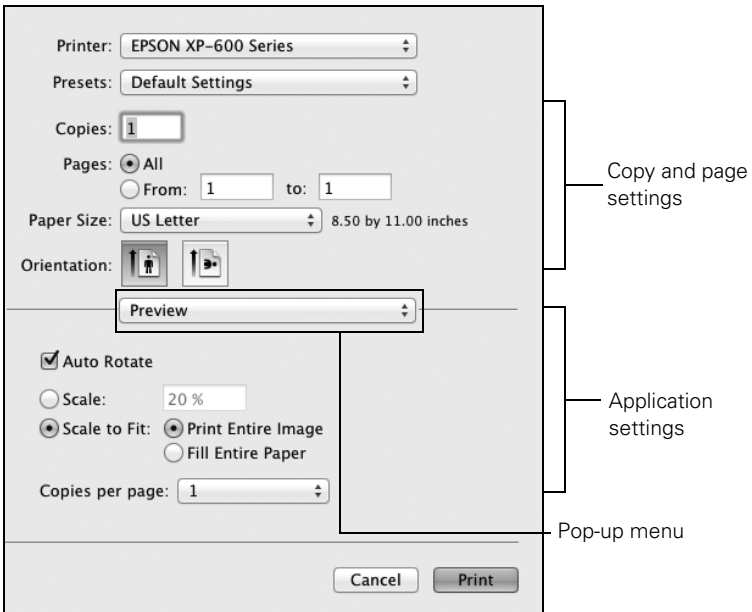

6. Choose **Print Settings** from the pop-up menu, and select your **Media Type**, **Print Quality**, and other print settings.
7. Choose any other printing options you may need from the pop-up menu. See the online *User's Guide* for details.
8. Click **Print**.
9. To monitor your print job, click the printer icon in the Dock.

Selecting the Correct Paper Type

Select the correct **Type** (Windows) or **Media Type** (Mac OS X) setting in your printer software. This tells your product what kind of paper you're using, so the ink coverage can be adjusted accordingly.

For this paper	Select this setting
Plain paper EPSON Bright White Paper EPSON Presentation Paper Matte EPSON Iron-on Cool Peel Transfer paper EPSON Photo Quality Self-adhesive Sheets	Plain Paper/Bright White Paper
EPSON Premium Photo Paper Glossy	Premium Photo Paper Glossy
EPSON Ultra Premium Photo Paper Glossy	Ultra Premium Photo Paper Glossy
EPSON Photo Paper Glossy	Photo Paper Glossy
EPSON Premium Photo Paper Semi-gloss EPSON Ultra Premium Photo Paper Luster	Premium Photo Paper Semi-Gloss
EPSON Premium Presentation Paper Matte EPSON Premium Presentation Paper Matte Double-sided EPSON Ultra Premium Presentation Paper Matte EPSON Brochure & Flyer Paper Matte Double-sided	Premium Presentation Paper Matte
Envelopes	Envelope





Scanning a Document or Photo

You can use your product to scan original documents or photos and save them on your computer.

Note: For detailed scanning instructions, see the online *User's Guide*.

Quick Scanning with the Touch Panel

Use the touch panel to quickly scan a photo or document and save it on your computer. You can even scan and send the image or document to an online service or to a remote printer.

1. Place your original document or photo as shown on page 9.
2. Close the cover gently so you don't move the original.
3. Press  if necessary, press  or  to select **Scan**, then press **OK**.
4. Press  or  and select one of the following options:
 - **Scan to Memory Card** automatically scans a photo or document and saves it to an inserted memory card or USB storage device.
 - **Scan to Cloud** sends your scanned files to a destination that you have registered with EPSON Connect.
 - **Scan to PC** automatically creates a JPG image and saves it to your computer; ideal for scanning photos.
 - **Scan to PC (PDF)** automatically creates a PDF file and saves it to your computer; ideal for scanning documents.
 - **Scan to PC (Email)** automatically scans a photo, resizes it, launches your email application, and attaches a JPG image to a new outgoing message. This works with MAPI-type email such as Microsoft® Outlook or Windows Live Mail, but not web-based email such as Gmail.
 - **Scan to PC (WSD)** lets you manage network scanning in Windows 7 or Windows Vista® (English only). To use this feature, you must first set up WSD (Web Services for Devices) on the computer.
5. Press **OK**.

6. If you're scanning to a memory card or USB storage device, select your scan settings then press \diamond to begin scanning.

If you're scanning to your computer, select **USB Connection** if your product is connected by a USB cable, or select the name of your computer if your product is connected over a network. Press \diamond to begin scanning.

Once your image is scanned, you see its icon on your computer screen, or as an attachment in your email application.

Scanning with EPSON Scan Software

You can scan original documents and photos and save them as files on your computer using the EPSON Scan software. You can also launch EPSON Scan from any TWAIN-compliant application.

Note: For Mac OS X 10.6 or 10.7, see "Scanning with Mac OS X 10.6 or 10.7" on page 18. For detailed scanning instructions, see the online *User's Guide*.

1. Place your original document or photo as shown on page 9.
2. Close the cover gently so you don't move the original.
3. Do one of the following to start EPSON Scan:
 - **Windows:** Double-click the EPSON Scan icon on your desktop.
 - **Mac OS X 10.5:** Double-click EPSON Scan in Applications > Epson Software.
 - To scan from an application, start your application. Then open the File menu, choose Import or Acquire, and select your EPSON product.

EPSON Scan opens in **Full Auto Mode** the first time you use it. (You can change the scan mode using the Mode selector in the upper right corner.)

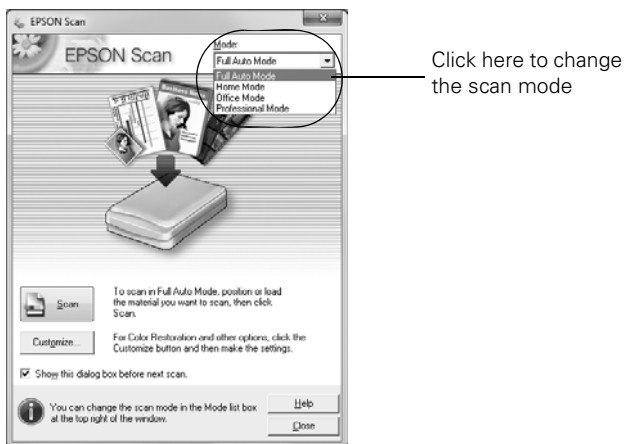

Note: If you want to automatically restore a color photo as you scan, click the **Customize** button, then check the **Color Restoration** box.

4. Click **Scan**. The image is scanned and you see its icon in the folder you have selected.

Scanning with Mac OS X 10.6 or 10.7

You can scan original documents and photos and save them as files on your computer.

1. Place your original document or photo as shown on page 9.
2. Close the cover gently so you don't move the original.
3. Open an image editing application such as Image Capture and select your product from the **DEVICES** or **SHARED** list, if necessary.
4. If you would like to select scan settings, such as Color Restoration and file save settings, click **Show Details**.
5. In the **Scan To** pop-up menu, select the folder in which you want to save your image.
6. Click the **Scan** button to begin scanning. Your image is saved to the folder selected.

Note: With Mac OS X 10.6 or 10.7, in addition to scanning with Image Capture, you can download and install EPSON Scan scanning software. EPSON Scan provides additional image adjustment and photo correction features for enhancing scanned images, and provides an interface for TWAIN-compliant OCR scanning software, such as ABBYY® FineReader®. To download EPSON Scan, visit Epson's driver download site **epson.com/support** (U.S.) or **epson.ca/support** (Canada).

Maintaining Your Product

Follow the instructions in this chapter to check and clean the print head nozzles, check ink levels, and replace ink cartridges. If you need to align the print head, see the online *User's Guide*.

Caution: To keep your product looking like new, don't place anything on top of the cover or use it as a writing surface. If you need to clean the cover, use only a soft, non-abrasive microfiber-type cloth.

Checking the Print Head Nozzles

If your printouts are faint or have gaps in them, some of the nozzles in the print head may be clogged or ink may be running low in one or more of the ink cartridges. Follow the steps below to check the print head nozzles.

1. Load a few sheets of plain paper in the lower paper cassette (cassette 2).
2. Press **⬆** if necessary, press **◀** or **▶** to select **Setup**, then press **OK**.
3. Press **▲** or **▼** to select **Maintenance**, press **OK**, select **Nozzle Check**, then press **OK** again.
4. Press **◇**. The nozzle check is printed.
5. Check the printed pattern to see if there are gaps in the lines:

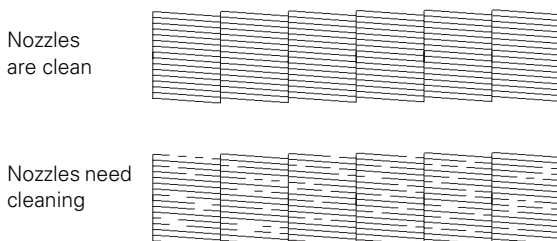







6. If there are no gaps, the print head is clean. Select **Done**, then press **OK**.
If there are gaps or the pattern is faint, press **▲** or **▼** to select **Clean the print head**, then press **OK**. Then follow the instructions on the screen to clean the print head (see page 20).

Cleaning the Print Head

If print quality has declined and the nozzle check indicates clogged nozzles, you can clean the print head. Print head cleaning uses ink, so clean it only if necessary.

Note: You cannot clean the print head if an ink cartridge is expended, and may not be able to clean it when a cartridge is low. You must replace the cartridge first (see page 22).

1. Load a few sheets of plain paper in the lower paper cassette (cassette 2).
2. Press  if necessary, press  or  to select **Setup**, then press **OK**.
3. Press  or  to select **Maintenance**, press **OK**, select **Head Cleaning**, then press **OK** again.
4. Press .

Cleaning takes a few minutes. When it's finished, you see a message on the display screen.

Caution: Never turn off the printer during head cleaning or you may damage it. Do not open the scanner unit or insert the CD/DVD tray during head cleaning.

5. Select **Print nozzle check pattern**, press **OK**, then press  to run a nozzle check and confirm that the print head is clean.
6. If there are still gaps or lines, or the test patterns are faint, run another cleaning cycle and check the nozzles again.



Note: If you don't see any improvement after cleaning the print head four times, turn off the printer and wait at least six hours to let any dried ink soften. Then try cleaning the print head again. If quality does not improve, one of the ink cartridges may need to be replaced. If that doesn't help, contact Epson as described on page 31.

If you do not use your printer often, it is a good idea to print a few pages at least once a month to maintain good print quality.

Checking Ink Levels

You can check the ink levels anytime right on the LCD screen. To check the ink levels with your Windows or Mac OS X software, see the instructions in your online *User's Guide*.

Note: You cannot print or copy when an ink cartridge is expended even if the other cartridges are not expended. Replace any expended cartridges before printing or copying.

1. Press  if necessary, press  or  to select **Setup**, then press **OK**.
2. Press **OK** again to select **Ink Levels**.

The ink cartridge status is displayed. See page 22 to replace a cartridge, if necessary.

3. Press **OK** to exit.

In Windows, a window may appear on your computer screen when you try to print when ink is low. This window can optionally display ink offers and other updates from Epson.

Note: To disable checking for ink offers or updates from Epson, see the instructions in your online *User's Guide*.

Purchasing EPSON Ink Cartridges

You can purchase genuine EPSON ink and paper from EPSON Supplies Central at www.epson.com/ink3 (U.S. sales) or www.epson.ca (Canadian sales). You can also purchase supplies from an EPSON authorized reseller. To find the nearest one, call 800-GO-EPSON (800-463-7766).

Use the following list when you order or purchase new ink cartridges (you can mix Standard- and High-capacity cartridges):

Ink color	Standard-capacity	High-capacity
Photo Black	273	273XL
Black	273	273XL
Cyan	273	273XL
Magenta	273	273XL
Yellow	273	273XL

Note: We recommend that you use genuine EPSON cartridges and do not refill them. The use of other products may affect your print quality and could result in printer damage.

Yields vary considerably based on images printed, print settings, paper type, frequency of use, and temperature. Actual yields will be lower with higher-density images, hot or dusty conditions, less frequent printing or printing predominantly with one color. All ink colors are used for printing and all-in-one printer maintenance, and all colors have to be installed for printing. For print quality, part of the ink from the included cartridges is used for printer startup and a variable amount of ink remains in the cartridges after the "replace cartridge" signal.

For best printing results, use up a cartridge within six months of opening the package, and before the expiration date on the cartridge box.

Store ink cartridges in a cool, dark place. If cartridges have been exposed to cold temperatures, allow them to warm up to room temperature for at least 3 hours before using them.

Replacing Ink Cartridges

Make sure you have a new ink cartridge before you begin. You must install new cartridges immediately after removing old ones.

Caution: Do not open ink cartridge packages until you are ready to install the ink. Cartridges are vacuum packed to maintain reliability.

Leave the expended cartridge installed until you have obtained a replacement, or the ink remaining in the print head nozzles may dry out.

Note: If you remove a low or expended ink cartridge, you cannot reinstall and use the cartridge.

1. Turn on your product.
2. If an ink cartridge is expended, you see a message on the LCD screen indicating which color to replace.

If you're replacing a cartridge before you see a message on the LCD screen, select **Setup > Ink Levels > Cartridge Replacement**.

Note: If a cartridge is expended, you must replace it to be able to print. If a cartridge is low, you can continue printing until a cartridge needs replacement.

3. Lift up the scanner unit.

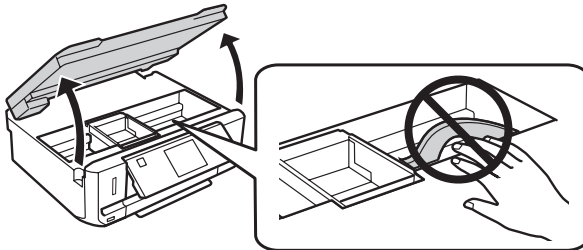

Caution: Do not move the print head by hand; otherwise, you may damage your product. Do not touch the flat white cable inside the printer.

4. Push in the blue tab to unlock the ink cartridge you are replacing. Then lift the bottom of the ink cartridge to remove it.

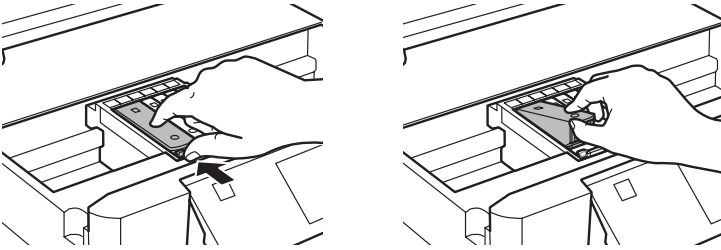

Warning: If ink gets on your skin, wash it off thoroughly with soap and water. If it gets in your eyes, flush them immediately with water. If you still have discomfort or vision problems, see a doctor immediately. Keep ink cartridges out of the reach of children and don't allow them to drink the ink.

5. Recap the ink cartridge using the cap that came with it. Dispose of it carefully. Do not take the used cartridge apart or try to refill it.

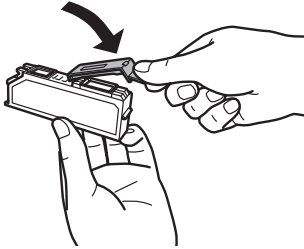

6. If you are replacing the Black (BK) ink cartridge, shake the new cartridge gently four or five times before unwrapping it. You do not need to shake the Photo Black (PBK) cartridge or any of the other color ink cartridges.

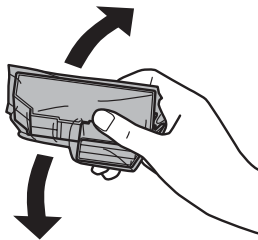

7. Open the new ink cartridge package.

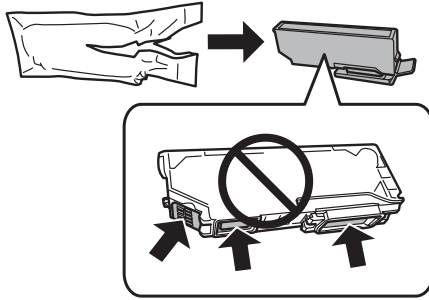

Caution: Do not touch the areas shown above. Doing so may prevent normal operation and printing.

Note: Do not shake cartridges after opening the package, as they may leak.

8. Remove the cap from the cartridge and store it in the included plastic bag for later use.

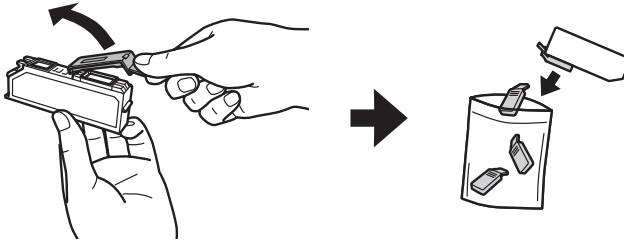



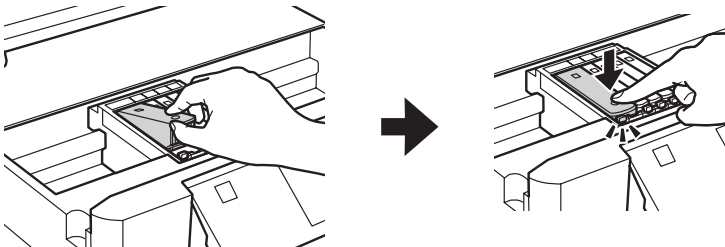

9. Insert the ink cartridge head first into the ink cartridge holder. Then press the bottom of the ink cartridge down until it clicks into place.



10. Once you replace all the cartridges that need replacing, close the scanner to begin priming the ink. This takes a few minutes. When you see a completion message on the LCD screen, ink priming is finished.

Caution: Never turn off your product while ink is priming or you'll waste ink. If you see an ink replacement message on the LCD screen, lift the scanner unit and press down on all the cartridges firmly. If printing on a CD or DVD, do not insert the CD/DVD tray until ink priming is finished.

Solving Problems

If you have a problem with your EPSON product, check the messages on the LCD screen to diagnose the cause of most problems. Press  if necessary, press  or  to select **Help**, then press **OK**. Press  or  to select **Troubleshooting**, then press **OK** to see all the help topics.

Note: If the screen is dark, press the touch panel to wake the printer from sleep mode.

You can also check the basic troubleshooting suggestions below, or in your online *User's Guide*. Or, access interactive troubleshooting and FAQs at epson.com/support (U.S.) or epson.ca/support (Canada).

Note: Breakdown or repair of this product may cause loss of network data and settings. Epson is not responsible for backing up or recovering data and settings during or after the warranty period. We recommend that you make your own backup or print out your network data and settings.





Network Problems

Note: For more detailed network instructions, see your online *User's Guide*.

- Try connecting to the wireless router or access point with your computer or another device to confirm that it is working correctly.
- Try restarting the router (turn it off and then on), then try to connect to it again.
- Print a Network Status Sheet (see page 28). Verify that the network settings are correct and check the signal strength. If it is poor, try moving the product closer to your router or access point. Avoid placing it next to a microwave oven, 2.4 GHz cordless phone, or large metal object such as a filing cabinet.
- If your wireless router doesn't broadcast its network name (SSID), see the following page for instructions on manually entering your wireless network name.
- If your wireless router has security enabled, make sure you entered the WEP key or WPA passphrase correctly.
- When using TCP/IP, make sure your network's DHCP option is enabled (your router manufacturer will be able to assist you with this setting).
- Remove and reinsert the CD to reinstall your product software.
- Disable the firewall temporarily to see if that may be causing the problem. Contact your firewall manufacturer for assistance.





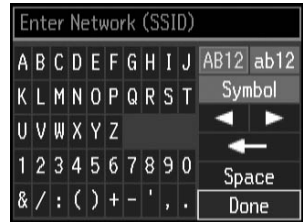

Connect the Printer to Your Wireless Network

If you are unable to connect to your wireless network using the product CD and the *Start Here* sheet, you can use the touch panel on your product. Before you start, make sure you know your network name (SSID) and password.

1. Press  if necessary, press  or  to select **Wi-Fi Setup**, then press **OK**.
2. Select **Wi-Fi Setup Wizard**, then press **OK**.
3. Press  or  until you see the name of your wireless network, select it, then press **OK**. Continue with step 6.

If you don't see your network name, select **Other Networks**, then press **OK**. You see this screen:



4. Enter your network name (SSID).
 - If your network name has uppercase (ABC) or lowercase (abc) letters, press  or , then press **OK** to enter them correctly.
 - Select  or , then press **OK** to move the cursor.
 - Select , then press **OK** to enter symbols.
 - Select , then press **OK** to delete.
 - Select , then press **OK** to enter a space.
5. Select **Done**, then press **OK** when you're finished entering your network name.
6. If your network has security enabled, you see the password screen:
7. Follow the instructions above to enter the password. If your network password has uppercase or lowercase letters, be sure to enter them correctly.
8. Select **Done**, then press **OK** when you're finished entering your password.

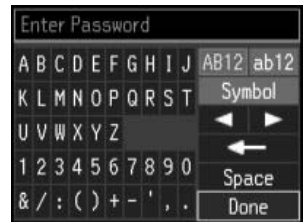









When the printer is connected to your network, the WiFi light should be green, and not flashing. Make sure you install the software on every computer from which you want to print. When prompted during software setup, select **The printer is already on my wireless network**.

Cannot Scan Over the Network

- EPSON Scan is not installed in Mac OS X 10.6 or 10.7; see page 18 for scanning and download instructions.
- If you cannot scan from the product's touch panel, make sure you restarted your computer after installing the product software. Make sure EPSON Event Manager is not being blocked by your firewall or security software. Try turning off the firewall.
- If you are scanning a large document at high resolution, a communication error may occur. If the scan did not complete, lower the scan resolution.
- If network communication was interrupted while starting EPSON Scan, exit EPSON Scan and restart it after a few seconds. If EPSON Scan cannot restart, turn the product off and on, and then try again. Check the **Timeout Setting** in **EPSON Scan Settings**. For details, see the EPSON Scan Help.
- Make sure EPSON Event Manager is set up to communicate with your product.

Print a Network Status Sheet

1. Press  if necessary, press  or  to select **Setup**, then press **OK**.
2. Press  or  to select **Wi-Fi/Network Settings**, then press **OK**.
3. Press  or  to select **Wi-Fi Status**, then press **OK**.
4. Press  twice to print the status sheet.

Printing and Copying Problems

- When loading paper in the paper cassettes, make sure it is loaded facedown (usually the whiter, brighter, or glossy side) and under the edge guides.
- Make sure the paper size and source selected on the touch panel or in your printer software is correct for the paper you loaded.
- When scanning, position your original with the bottom against the front right corner of the scanner glass. If the edges are cropped, move it away from the corner slightly.
- You cannot print or copy when an ink cartridge is expended. Replace any expended cartridges before printing.
- To select two-sided printing in Mac OS X, choose **2-sided Settings** from the pop-up menu. Do not select **Layout** from the pop-up menu.

Paper Feeding Problems

- If paper doesn't feed correctly, remove the paper and fan the sheets, then reload them as shown on page 4. Make sure paper is loaded under the edge guides.
- Do not load more than the recommended number of sheets. See your online *User's Guide* for information on paper loading capacity.
- If paper has jammed, follow the steps on the LCD screen. If necessary, check the following areas:
 1. Lift the scanner unit and carefully remove any paper trapped inside.

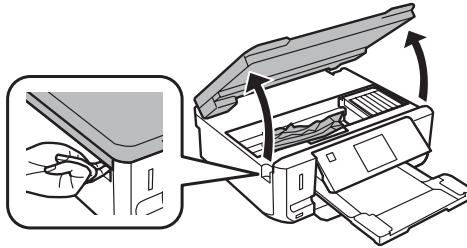

2. Remove the paper cassettes, then remove any jammed paper trapped inside.

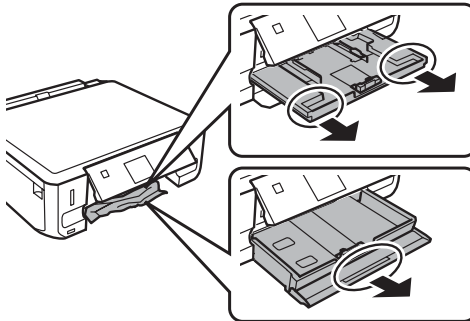

3. Remove the auto-duplexer from the back of the printer and check for any jammed paper.

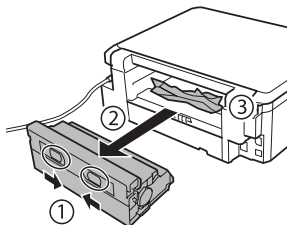

4. Remove any paper stuck in the auto-duplexer.

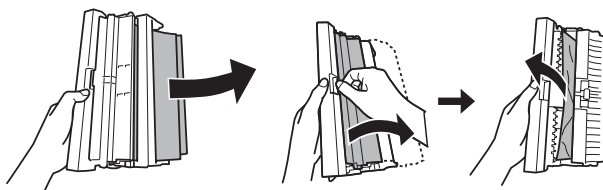

Print Quality Problems

- Load the paper printable side down (usually the whiter, brighter, or glossy side) in the paper cassettes.
- Make sure your paper isn't damp or curled.
- For the best print quality, use EPSON papers (see page 7) and genuine EPSON ink cartridges (see page 21).
- Make sure the type of paper you loaded matches the paper type setting on the touch panel or in your printer software (see page 15).
- If you notice light or dark bands across your printouts or they are too faint, run a nozzle check (see page 19) to see if the print head needs cleaning.
- If you notice jagged vertical lines, you may need to align the print head. See the online *User's Guide* for instructions.
- The ink cartridges may be low on ink. Check your cartridge status and replace cartridges, if necessary (see page 22).
- Clean the scanner glass with a soft, dry, lint-free cloth (paper towels are not recommended), or use a small amount of glass cleaner on a soft cloth, if necessary. Do not spray glass cleaner directly on the glass.

Where to Get Help

Internet Support

Visit epson.com/support (U.S.) or epson.ca/support (Canada) for solutions to common problems. You can download drivers and documentation, get FAQs and troubleshooting advice, or e-mail Epson.

Speak to a Support Representative

Before you call Epson for support, please have the following information ready:

- Product name (XP-600)
- Product serial number (located on the back of the product and under the scanner)
- Proof of purchase (such as a store receipt) and date of purchase
- Computer configuration and description of the problem

Then call: (562) 276-4382 (US) or (905) 709-3839 (Canada) 6 AM – 8 PM, Pacific Time, Monday through Friday, and 7 AM – 4 PM, Pacific Time, Saturday.

Days and hours of support are subject to change without notice. Toll or long distance charges may apply.



Purchase Supplies and Accessories

You can purchase genuine EPSON ink and paper at EPSON Supplies Central at www.epson.com/ink3 (U.S. sales) or www.epson.ca (Canadian sales). You can also purchase supplies from an EPSON authorized reseller. To find the nearest one, call 800-GO-EPSON (800-463-7766).

Notices

Important Safety Instructions

Before using your EPSON product, read and follow these safety instructions:

- Be sure to follow all warnings and instructions marked on the product.
- Use only the type of power source indicated on the product label.
- Use only the power cord that comes with the product. Use of another cord may cause fires or electric shock. Do not use the cord with any other equipment. Make sure the power cord meets all relevant local safety standards.
- The product's power cord is for use with the product only. Use with other equipment may cause fire or electric shock.
- Place the product near a wall outlet where the plug can be easily unplugged.
- If you won't be using the product for a long period, unplug the power cord from the electrical outlet.
- Always turn off the product using the  power button, and wait until the  power light stops flashing before unplugging the product or cutting off power to the electrical outlet.
- Avoid plugging the product into an outlet on the same circuit as a photocopier or air conditioning system that regularly switches on and off, or on an outlet controlled by a wall switch or timer.
- Do not let the power cord become damaged or frayed. Place it to avoid abrasions, cuts, fraying, crimping, and kinking. Do not place objects on top of it and do not allow it to be stepped on or run over. Be careful to keep the cord straight at each end. If damage occurs to the plug, replace the cord or consult a qualified electrician. If there are fuses in the plug, make sure you replace them with fuses of the correct size and rating.
- If you use an extension cord with the product, make sure the total ampere rating of the devices plugged into the extension cord does not exceed the cord's ampere rating. Also, make sure the total ampere rating of all devices plugged into the wall outlet does not exceed the wall outlet's ampere rating.
- When connecting the product to a computer or other device with a cable, ensure the correct orientation of the connectors. Each connector has only one correct orientation. Inserting a connector in the wrong orientation may damage both devices connected by the cable.
- Place the product on a flat, stable surface that extends beyond its base in all directions. It will not operate properly if it is tilted or at an angle.
- Avoid placing the product in locations that are subject to rapid changes in heat or humidity, shocks or vibrations, or dust. Do not place the product near a radiator or heating vent or in direct sunlight. Do not place or store the product outdoors.
- Keep the product away from potential sources of electromagnetic interference, such as loudspeakers or the base units of cordless phones.

- Allow space behind the product for the cables, and space above the product so that you can fully raise the document cover.
- Leave enough space in front of the product for the paper to be fully ejected.
- Leave enough room around the product for sufficient ventilation. Make sure the product is at least 4 inches (10 cm) away from the wall.
- Do not block or cover openings in the product case or insert objects through the slots.
- Do not use aerosol products that contain flammable gases inside or around the product. Doing so may cause fire.
- Do not press too hard on the scanner glass when placing the originals.
- Do not open the scanner section while the product is copying, printing, or scanning.
- Be careful not to trap your fingers when closing the scanner cover or scanner.
- Do not touch the flat white cable inside the product.
- Do not spill liquid on the product. Do not use the product near water. Do not use with wet hands.
- Unplug the product and refer servicing to qualified service personnel under the following conditions: if the power cord or plug is damaged; if liquid has entered the product; if the product has been dropped or the case damaged; if the product does not operate normally or exhibits a distinct change in performance.
- Adjust only those controls that are covered by the operating instructions. Except as specifically explained in your documentation, do not attempt to service the product yourself.
- Never disassemble, modify, or attempt to repair the product by yourself, except as specifically explained in the documentation. Do not adjust controls that are not covered by the operating instructions.
- When storing or transporting the product, do not tilt it, stand it on its side, or turn it upside down; otherwise ink may leak from the cartridges.
- Always keep this guide handy.

Touch Panel Safety

- Press the touch panel gently with your fingertip. Do not press with force or use your fingernail.
- The LCD screen may contain a few small bright or dark spots or uneven brightness. This is normal and does not indicate that the touch panel is damaged in any way.
- Use only a dry, soft cloth to clean the touch panel. Do not use liquid or chemical cleansers.
- Do not use items such as ball point pens, pencils, etc. to operate the touch panel.
- Do not touch the panel with wet or gloved hands or through the protective sheet or sticker; it may not respond.
- Do not place heavy items on the touch panel. Contact Epson if the panel chips or cracks; do not attempt to remove broken pieces.
- Do not place your product in areas where abrupt changes in temperature or humidity may occur. Condensation inside the panel may cause performance to deteriorate.

- If the touch panel is damaged, contact Epson. If the liquid crystal solution gets on your hands, wash them thoroughly with soap and water. If the liquid crystal solution gets into your eyes, flush them immediately with water. If discomfort or vision problems remain after a thorough flushing, see a doctor immediately.

Memory Card Safety

- Use only compatible memory cards (see the *User's Guide* for a detailed list).
- Do not remove a memory card or turn off the product while the memory card light is flashing.

Wireless Network Safety

- Do not use this product inside medical facilities or near medical equipment. Radio waves from the product may adversely affect the operation of medical equipment.
- Do not use this product near automatically controlled devices such as automatic doors or fire alarms. Radio waves from this product may adversely affect these devices.
- To avoid adversely affecting the operation of the following equipment and causing an accident, do not use the product: near medical equipment in a medical facility; within 8.7 inches (22 cm) of a cardiac pacemaker; near automatically controlled devices, such as automatic doors or fire alarms.

Ink Cartridge Safety

- Keep ink cartridges out of the reach of children and don't allow them to drink the ink.
- Be careful when you handle used ink cartridges; there may be ink remaining around the ink supply port. If ink gets on your skin, wash it off thoroughly with soap and water. If it gets in your eyes, flush them immediately with water. If you still have discomfort or vision problems, see a doctor immediately. If ink gets in your mouth, spit it out and see a doctor right away.
- Do not put your hand inside the product or touch any cartridges during printing.
- Do not try to move the print head by hand, or you may damage the product.
- Do not touch the green IC chip on the side of the cartridge. This may prevent normal operation.
- Before transporting the product, make sure the print head is in the home (far right) position and the ink cartridges are in place.
- Install a new ink cartridge immediately after removing a used one. Leaving cartridges uninstalled can dry out the print head and may prevent the product from printing.
- Do not dismantle an ink cartridge. This could damage the print head.
- Use the ink cartridge before the date printed on its package.
- If you remove an ink cartridge for later use or disposal, make sure you put the cap back on the cartridge's ink supply port to prevent ink from drying out or to prevent surrounding areas from getting smeared by ink.

- Store ink cartridges in a cool, dry place.
- After bringing an ink cartridge in from a cold storage site, allow it to warm up at room temperature for at least 3 hours before using it.
- Although the ink cartridges may contain recycled materials, this does not affect product function or performance.

Declaration of Conformity

According to 47CFR, Part 2 and 15 for: Class B Personal Computers and Peripherals; and/or CPU Boards and Power Supplies used with Class B Personal Computers:

We: Epson America, Inc.
Located at: MS 3-13
3840 Kilroy Airport Way
Long Beach, CA 90806
Telephone: (562) 290-5254

Declare under sole responsibility that the product identified herein, complies with 47CFR Part 2 and 15 of the FCC rules as a Class B digital device. Each product marketed is identical to the representative unit tested and found to be compliant with the standards. Records maintained continue to reflect the equipment being produced can be expected to be within the variation accepted, due to quantity production and testing on a statistical basis as required by 47CFR §2.909. Operation is subject to the following two conditions: (1) this device may not cause harmful interference, and (2) this device must accept any interference received, including interference that may cause undesired operation.

Trade Name: Epson
Type of Product: Multifunction printer
Model: C491E

FCC Compliance Statement

For United States Users

This equipment has been tested and found to comply with the limits for a Class B digital device, pursuant to Part 15 of the FCC Rules. These limits are designed to provide reasonable protection against harmful interference in a residential installation. This equipment generates, uses, and can radiate radio frequency energy and, if not installed and used in accordance with the instructions, may cause harmful interference to radio or television reception. However, there is no guarantee that interference will not occur in a particular installation. If this equipment does cause interference to radio and television reception, which can be determined by turning the equipment off and on, the user is encouraged to try to correct the interference by one or more of the following measures:

- Reorient or relocate the receiving antenna.

- Increase the separation between the equipment and receiver.
- Connect the equipment into an outlet on a circuit different from that to which the receiver is connected.
- Consult the dealer or an experienced radio/TV technician for help.

WARNING

The connection of a non-shielded equipment interface cable to this equipment will invalidate the FCC Certification of this device and may cause interference levels which exceed the limits established by the FCC for this equipment. It is the responsibility of the user to obtain and use a shielded equipment interface cable with this device. If this equipment has more than one interface connector, do not leave cables connected to unused interfaces. Changes or modifications not expressly approved by the manufacturer could void the user's authority to operate the equipment.

For Canadian Users

This Class B digital apparatus complies with Canadian ICES-003.

Cet appareil numérique de la classe B est conforme à la norme NMB-003 du Canada.

Epson America, Inc., Limited Warranty

What Is Covered: Epson America, Inc. ("Epson") warrants to the original retail purchaser that the Epson printer covered by this limited warranty statement, if purchased and operated only in the United States, Canada, or Puerto Rico, will be free from defects in workmanship and materials for a period of one (1) year from the date of original purchase. For warranty service, you must provide proof of the date of original purchase.

What Epson Will Do To Correct Problems: Should your Epson printer prove defective during the warranty period, please call the EPSON ConnectionSM at (562) 276-4382 (U.S.) or (905) 709-3839 (Canada) for warranty repair instructions and return authorization. An EPSON service technician will provide telephone diagnostic service to determine whether the printer requires service. If service is needed, Epson will, at its option, exchange or repair the printer without charge for parts or labor. If Epson authorizes an exchange for the defective unit, Epson will ship a replacement printer to you, freight prepaid, so long as you use an address in the United States, Canada, or Puerto Rico. Shipments to other locations will be made freight collect. You are responsible for securely packaging the defective unit and returning it to Epson within five (5) working days of receipt of the replacement. Epson requires a debit or a credit card number to secure the cost of the replacement printer in the event that you fail to return the defective one. If Epson authorizes repair instead of exchange, Epson will direct you to send your printer to Epson or its authorized service center, where the printer will be repaired and sent back to you. You are responsible for packing the printer and for all costs to and from the EPSON authorized service center. When warranty service involves the exchange of the printer or a part, the item replaced becomes Epson property. The replacement

printer or part may be new or refurbished to the Epson standard of quality, and, at Epson's option, may be another model of like kind and quality. Exchange products and parts assume the remaining warranty period of your original product covered by this limited warranty.

What This Warranty Does Not Cover: This warranty covers only normal use in the United States, Canada, or Puerto Rico. Using this product for continuous production or similar high duty purposes is not considered normal use; damage, maintenance or service from such use will not be covered under this warranty. This warranty is not transferable. This warranty does not cover any color change or fading of prints or reimbursement of materials or services required for reprinting. This warranty does not cover damage to the EPSON product caused by parts or supplies not manufactured, distributed or certified by Epson. This warranty does not cover ribbons, ink cartridges or third party parts, components, or peripheral devices added to the EPSON product after its shipment from Epson, e.g., dealer or user-added boards or components. Epson is not responsible for warranty service should the Epson label or logo or the rating label or serial number be removed or should the product fail to be properly maintained or fail to function properly as a result of misuse, abuse, improper installation, neglect, improper shipping, damage caused by disasters such as fire, flood, and lightning, improper electrical current, software problems, interaction with non-EPSON products, or service other than by an EPSON Authorized Servicer. If a claimed defect cannot be identified or reproduced, you will be held responsible for the costs incurred.

THE WARRANTY AND REMEDY PROVIDED ABOVE ARE EXCLUSIVE AND IN LIEU OF ALL OTHER EXPRESS OR IMPLIED WARRANTIES INCLUDING, BUT NOT LIMITED TO, THE IMPLIED WARRANTIES OF MERCHANTABILITY, NON-INFRINGEMENT OR FITNESS FOR A PARTICULAR PURPOSE. SOME LAWS DO NOT ALLOW THE EXCLUSION OF IMPLIED WARRANTIES. IF THESE LAWS APPLY, THEN ALL EXPRESS AND IMPLIED WARRANTIES ARE LIMITED TO THE WARRANTY PERIOD IDENTIFIED ABOVE. UNLESS STATED HEREIN, ANY STATEMENTS OR REPRESENTATIONS MADE BY ANY OTHER PERSON OR FIRM ARE VOID. IN NO EVENT SHALL EPSON OR ITS AFFILIATES BE LIABLE FOR ANY SPECIAL, INCIDENTAL OR CONSEQUENTIAL DAMAGES RESULTING FROM THE USE OR INABILITY TO USE THE EPSON PRODUCT, WHETHER RESULTING FROM BREACH OF WARRANTY OR ANY OTHER LEGAL THEORY. IN NO EVENT SHALL EPSON OR ITS AFFILIATES BE LIABLE FOR DAMAGES OF ANY KIND IN EXCESS OF THE ORIGINAL RETAIL PURCHASE PRICE OF THE PRODUCT.

In Canada, warranties include both warranties and conditions.

Some jurisdictions do not allow limitations on how long an implied warranty lasts, and some jurisdictions do not allow the exclusion or limitation of incidental or consequential damages, so the above limitations and exclusions may not apply to you. This warranty gives you specific legal rights and you may have other rights which vary from jurisdiction to jurisdiction.

To find the EPSON Authorized Reseller nearest you, visit our website at: www.epson.com.

To find the EPSON Customer Care Center nearest you, visit www.epson.com/support.

You can also write to: Epson America, Inc., P.O. Box 93012, Long Beach, CA 90809-3012

Copyright Notice

All rights reserved. No part of this publication may be reproduced, stored in a retrieval system, or transmitted in any form or by any means, electronic, mechanical, photocopying, recording, or otherwise, without the prior written permission of Seiko Epson Corporation. The information contained herein is designed only for use with this Epson product. Epson is not responsible for any use of this information as applied to other equipment.

Neither Seiko Epson Corporation nor its affiliates shall be liable to the purchaser of this product or third parties for damages, losses, costs, or expenses incurred by purchaser or third parties as a result of: accident, misuse, or abuse of this product or unauthorized modifications, repairs, or alterations to this product, or (excluding the U.S.) failure to strictly comply with Seiko Epson Corporation's operating and maintenance instructions.

Seiko Epson Corporation shall not be liable for any damages or problems arising from the use of any options or any consumable products other than those designated as Original Epson Products or Epson Approved Products by Seiko Epson Corporation.

In addition to software program rights owned by Seiko Epson Corporation, this product also includes open source software. Refer to OSS.pdf on your product software CD-ROM for a list of open source software and software license terms applied to this printer.

Responsible Use of Copyrighted Materials

Epson encourages each user to be responsible and respectful of the copyright laws when using any Epson product. While some countries' laws permit limited copying or reuse of copyrighted material in certain circumstances, those circumstances may not be as broad as some people assume. Contact your legal advisor for any questions regarding copyright law.

Trademarks

EPSON and Supplies Central are registered trademarks, EPSON Connect is a trademark, and EPSON Exceed Your Vision is a registered logomark of Seiko Epson Corporation.

EPSON Connection is a service mark and Small-in-One is a trademark of Epson America, Inc.

General Notice: Other product names used herein are for identification purposes only and may be trademarks of their respective owners. Epson disclaims any and all rights in those marks.

This information is subject to change without notice.

© 2012 Epson America, Inc. 5/12



412328500

CPD-37279
Printed in XXXXXX